

ZXLD1937

ADJUSTABLE LED DRIVER WITH INTERNAL SWITCH IN TSOT23-5

DESCRIPTION

The ZXLD1937 is a PFM inductive boost converter designed for driving 2, 3 or 4 series connected white LEDs from a Li-Ion cell and up to 8 LEDs from a 5V supply. The device operates from an input supply of between 2.5V and 5.5V and provides an adjustable output current of up to 50mA.

The ZXLD1937 includes the output switch and peak current sense resistor, and can operate with a maximum output voltage of 28V.

Quiescent current is typically 60 μ A and a shutdown function is provided to reduce this current to less than 500nA in the 'off' state.

Output current can be adjusted by applying a PWM control signal to the 'Enable' pin. Depending upon the control frequency, this will provide either a continuous or a 'chopped' output current. The PWM filter components are contained within the chip.

The device is assembled in the TSOT23-5 pin package with 1mm maximum height profile.

ADVANCED FEATURES

- True Analog Dimming via PWM

FEATURES

- 1mm height profile TSOT23-5 pin package
- Internal PWM filter for flicker free output
- High efficiency (80% typ)
- Wide input voltage range: 2.5V to 5.5V
- Up to 50mA output current
- Low quiescent current: (60 μ A typ)
- 500nA maximum shutdown current
- Up to 1MHz switching frequency
- Low external component count
- Inherently matched LED currents

APPLICATIONS

- Mobile phones
- Digital cameras
- PDAs
- LCD modules
- Portable internet appliances
- Palmtop computers

PIN CONNECTIONS

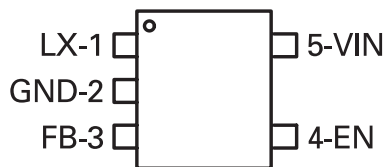

TYPICAL APPLICATION CIRCUIT

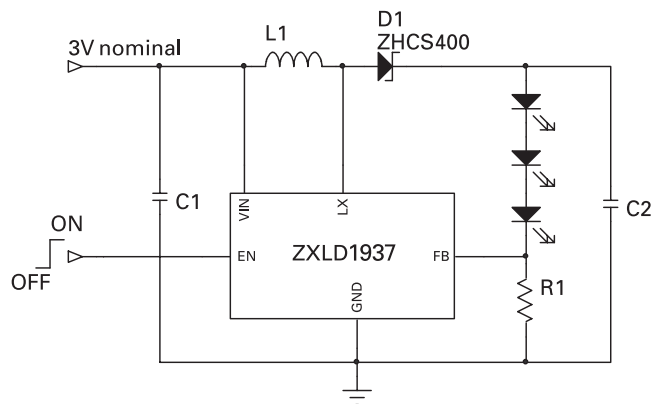

ZXLD1937

ORDERING INFORMATION

DEVICE	DEVICE DESCRIPTION	TEMPERATURE RANGE	PART MARK	TAPING OPTIONS
ZXLD1937ET5	Boost converter in TSOT23-5	-40°C to +85°C	1937	TA, TC

ZXLD1937ET5TA for 7" reel of 3,000 devices

ZXLD1937ET5TC for 13" reel of 10,000 devices

ABSOLUTE MAXIMUM RATINGS (Voltages to GND unless otherwise stated)

PARAMETER	SYMBOL	LIMIT	UNIT
Input voltage	(V_{IN})	7	V
LX output voltage	(V_{LX})	30	V
Switch output current	(I_{LX})	500	mA
Power dissipation	(PD)	300	mW
Operating temperature	(T_{OP})	-40 to 85	°C
Storage temperature	(T_{ST})	-55 to 150	°C
Junction temperature	($T_{J\ MAX}$)	125	°C

NOTES:

Operation above the absolute maximum may cause device failure. Operation at the absolute maximum ratings for extended periods may reduce device reliability.

ZXLD1937

ELECTRICAL CHARACTERISTICS (at $V_{IN} = 3V$, $T_{amb} = 25^{\circ}C$ unless otherwise stated⁽¹⁾)

SYMBOL	PARAMETER	CONDITIONS	MIN.	TYP.	MAX.	UNIT
V_{IN}	Input voltage		2.5		5.5	V
I_{IN}	Supply current					
	Quiescent	$V_{EN} = V_{IN}$, $I_{LX} = 0$, Output not switching		60	100	μA
	Shutdown	$V_{EN} = 0V$			500	nA
V_{FB}	FB pin control voltage		90.5		109.5	mV
I_{FB}	FB pin input current				100	nA
f_{LX}	Operating frequency	$L=10\mu H$, $V_{OUT}=10V$, $I_{OUT}=20mA$		0.35	1	MHz
T_{OFF}	LX output 'OFF' time		350	500		ns
T_{ON}	LX output 'ON' time ⁽²⁾				5	μs
I_{LXpk}	Switch peak current limit	$L=10\mu H$, $V_{OUT}=10V$, $I_{OUT}=20mA$		320		mA
R_{LX}	Switch 'On' resistance			1.5		Ω
$I_{LX(leak)}$	Switch leakage current	$V_{LX} = 20V$			1	μA
V_{OUT}	Controller output voltage	Normal operation			28	V
V_{ENH}	EN pin High level Input voltage	Device active	1.5		V_{IN}	V
V_{ENL}	EN pin Low level Input voltage	Device in shutdown			0.4	V
I_{ENL}	EN pin Low level input current	$V_{EN} = 0V$			-100	nA
I_{ENH}	EN pin High level input current	$V_{EN} = V_{IN}$			1	μA
$T_{EN(hold)}$	EN pin turn off delay ⁽³⁾	V_{EN} switched from high to low		120		μs
$\Delta T/T$	PWM duty cycle range at 'EN' input for filtered PWM control ⁽⁴⁾	$10kHz < f < 100kHz$, $V_{ENH} = V_{IN}$	20		100	%
f_{LPF}	Internal PWM low pass filter cut-off frequency			4		kHz
A_{LPF}	Filter attenuation	$f=30kHz$		52.5		dB
$\Delta T/T$	PWM duty cycle range at 'EN' input for 'gated' output current control ⁽⁵⁾	$f < 1kHz$, $V_{ENH} = V_{IN}$	0		100	%

NOTES:

- (1) Production testing of the device is performed at 25°C. Functional operation of the device over a -40°C to +85°C temperature range is guaranteed by design, characterisation and process control.
- (2) Nominal 'on' time (T_{ONnom}) is defined by the input voltage (V_{IN}), coil inductance (L) and peak current (I_{LXpkdc}) according to the expression:
 $T_{ONnom} = (I_{LX(pkdc)} \times L / V_{IN}) + 200ns$.
- (3) This is the time for which the device remains active after the EN pin has been asserted low. This delay is necessary to allow the output to be maintained during dc PWM mode operation.
- (4) The minimum PWM signal frequency during this mode of operation is to ensure that the device remains active during PWM control. This provides a continuous dc output current. For lower frequencies, the device will be gated 'on' and 'off' during PWM control.
- (5) The maximum PWM signal frequency during this mode of operation should be kept as low as possible to minimise errors due to the turn-off delay of the device (see Enable pin turn-off delay).

ZXLD1937

PIN DESCRIPTION

PIN NO.	NAME	DESCRIPTION
1	LX	Output of NDMOS switch
2	GND	Ground (0V)
3	FB	Feedback pin for current control loop (connect resistor R1 from this pin to GND for output current $I = 100\text{mV} / R1$)
4	EN	Enable input (active high to turn on device) Also used to adjust output current by PWM signal Connect to V_{in} for permanent operation
5	V_{IN}	Input voltage (2.5V to 5.5V). Decouple with capacitor close to device

BLOCK DIAGRAM

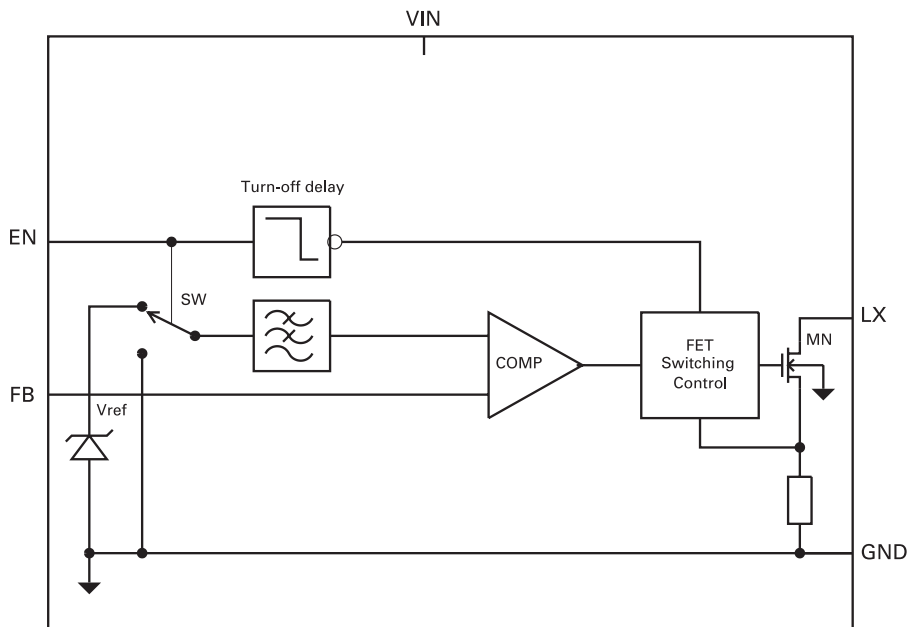

DEVICE DESCRIPTION

The device is a PFM flyback dc-dc boost converter, working in discontinuous mode.

With reference to the chip block diagram and typical application circuit, the operation of the device is as follows:

Control loop

When 'EN' is high, the control circuits become active and the low side of the coil (L1) is switched to ground via NDMOS transistor (MN). The current in L1 is allowed to build up to an internally defined level (nominally 320mA) before MN is turned off. The energy stored in L1 is then transferred to the output capacitor (C2) via schottky diode (D1). When the voltage on C2 has risen above the threshold voltage of the series connected LEDs, current will flow through external sense resistor R1. The voltage developed across R1 is sensed at pin 'FB' and compared to a 100mV reference voltage (V_{REF}). A comparator senses when the feedback voltage is above V_{REF} and its output is used to control the 'off' time of the output switch. The control loop is self-oscillating, producing pulses of up to 5 μ s maximum duration (switch 'on'), at a frequency that varies in proportion to the LED current. The feedback loop maintains a voltage of V_{REF} at the FB pin and therefore defines a maximum LED current equal to V_{REF} divided by R1. The minimum 'off' time of the output switch is fixed at 0.5 μ s nominal, to allow time for the coil's energy to be dissipated before the switch is turned on again. This maintains stable and efficient operation in discontinuous mode.

Filtered PWM operation

The input of an internal low pass filter is switched to V_{REF} when the EN pin is high and switched to ground when the EN pin is low. The output of this filter drives the comparator within the control loop. A continuous high state on EN therefore provides a filtered voltage of value V_{REF} to the comparator. However, by varying the duty cycle of the EN signal at a suitably high frequency ($f > 10\text{kHz}$), the control loop will see a voltage, that has an average value equal to the duty cycle multiplied by V_{REF} . This provides a means of adjusting the output current to a lower value. It also allows the device to be both turned on and adjusted with a single signal at the 'EN' pin. The output during this mode of operation will be a dc current equal to $(V_{REF} / R1) \times \text{duty cycle}$

Gated PWM operation

The internal circuitry of the ZXLD1937 is turned off when no signal is present on the 'EN' pin for more than 120 μ s (nominal). A low frequency signal applied to the EN pin will therefore gate the device 'on' and 'off' at the gating frequency and the duty cycle of this signal can be varied to provide a 'chopped' output current equal to $(V_{REF} / R1) \times \text{duty cycle}$. For best accuracy, the gating frequency should be made as low as possible (e.g. below 1kHz), such that the turn off delay of the chip is only a small proportion of the gating period

Further details of setting output current are given in the applications section under brightness control.

ZXLD1937

TYPICAL CHARACTERISTICS

(For typical application circuit at $V_{IN}=3V$ and $T_A=25^\circ C$ unless otherwise stated)

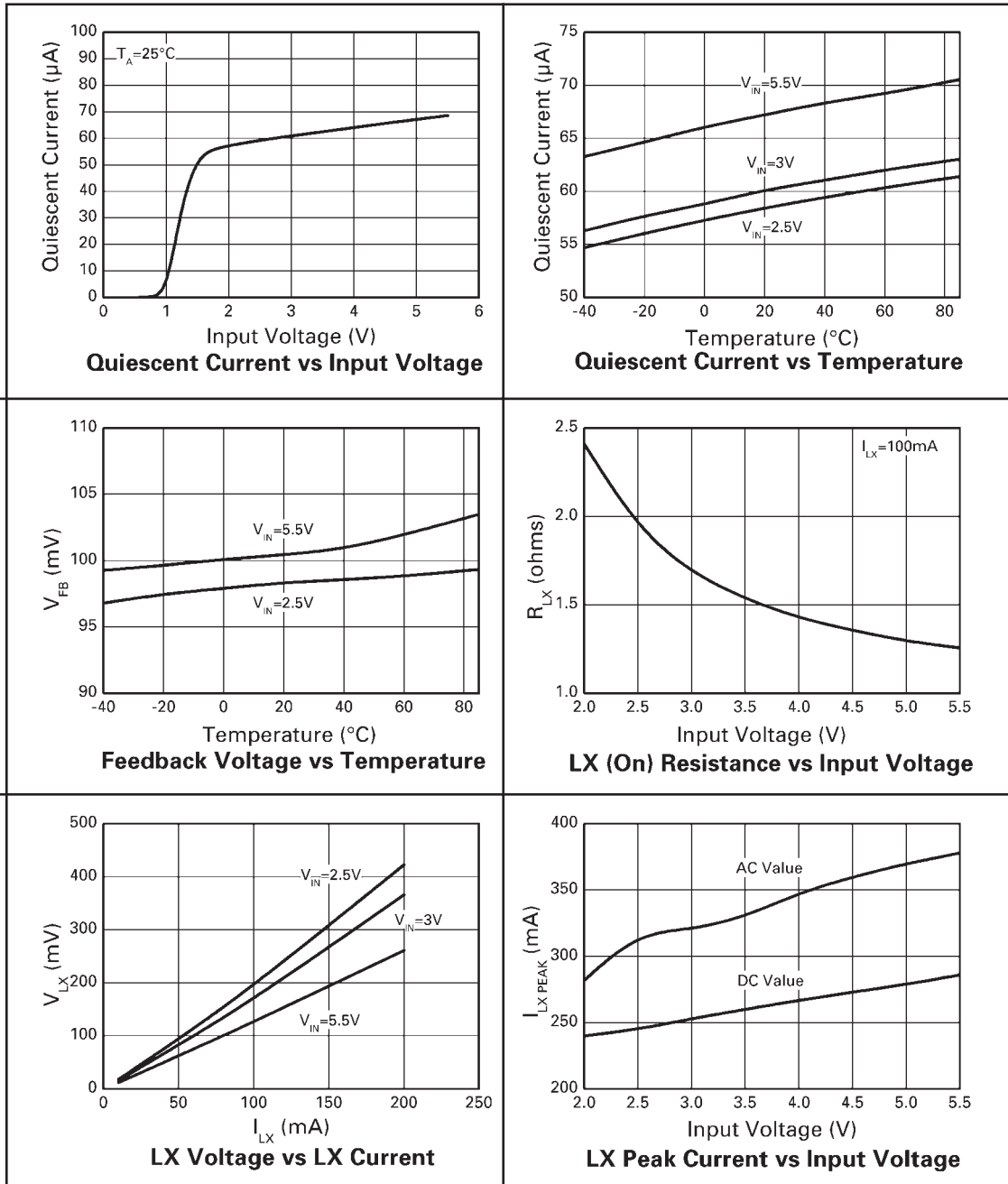

ZXLD1937

TYPICAL OPERATING CHARACTERISTICS

(For typical applications circuit at $V_{IN}=3V$, $L=10\mu H$ Coilcraft DO1608C Series, 3 series LEDs, $I_{LED}=15mA$, $T_A=25^\circ C$ unless otherwise stated)

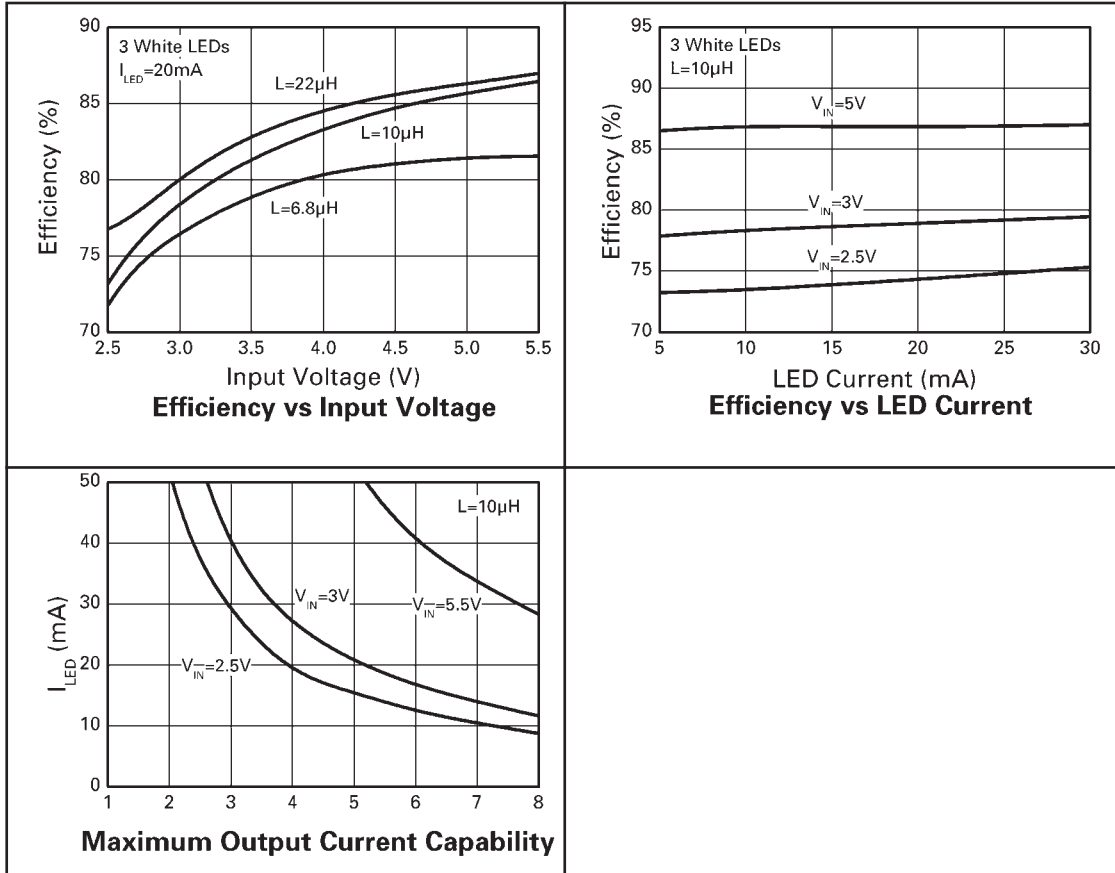

ZXLD1937

APPLICATIONS

Programming the maximum LED current

The maximum LED current is programmed by adding a single resistor in series with the LED chain. The current is determined by the resistor value and feedback voltage and is given by:

$$I_{LED} = V_{FB}/R1$$

$$\text{where } V_{FB}=100\text{mV}$$

The table below gives recommended resistor values for required LED currents:

LED Current	R1 Value
10mA	10Ω
15mA	6.8Ω
20mA	5Ω
30mA	3.3Ω

Dimming Control via a PWM signal on the EN pin

A Pulse Width Modulated (PWM) signal can be applied to the EN pin in order to adjust the output current to a value below the maximum LED current. Two modes of adjustment are possible as described below.

True Analog Dimming - Filtered 'DC' mode

If a PWM signal of 10kHz or higher is applied to the EN pin, the device will remain active when the EN pin is low. However, the input to the internal low pass filter will be switched alternately from V_{REF} to ground, with a duty cycle (D) corresponding to that of the PWM signal. This will present a filtered dc voltage equal to the duty cycle multiplied by V_{REF} to the control loop and will produce a dc output current lower than the maximum set value. This current is given by:

$$I_{OUTdc} = 0.1D/R1$$

This mode of adjustment minimizes flicker in the light output and system noise.

Pulsed Dimming - Gated Mode

If a lower frequency of 1kHz or less is applied to the EN pin, the device will be gated 'on' and 'off' at a duty cycle (D) corresponding to that of the input signal. The average output current is then given by:

$$I_{OUTavg} \approx 0.1D/R1$$

This mode may be preferred over dc current control if the purest white output is required. However, note the 120μs nominal turn-off delay of the device, when using the device in this mode.

ZXLD1937

Dimming Control using a DC voltage

For applications where the EN pin is not available a DC voltage can be used to control dimming. By adding resistors R2 and R3 and applying a DC voltage, the LED current can be adjusted from 100% to 0%. As the DC voltage increases, the voltage drop across R2 increases and the voltage drop across R1 decreases, thus reducing the current through the LEDs. Selection of R2 and R3 should ensure that the current from the DC voltage is much less than the LED current and much larger than the feedback current. The component values in the diagram below represent 0% to 100% dimming control from a 0 to 2V DC voltage.

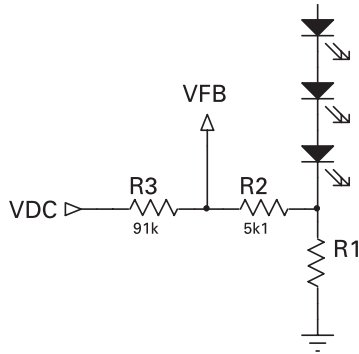

Dimming Control using a filtered PWM signal

The filtered PWM signal can be considered as an adjustable DC voltage by applying a RC filter. The values shown in the diagram below are configured to give 0% to 100% dimming for a 1kHz to 100kHz PWM signal with a 2V amplitude. e.g. a 50% duty cycle will give 50% dimming.

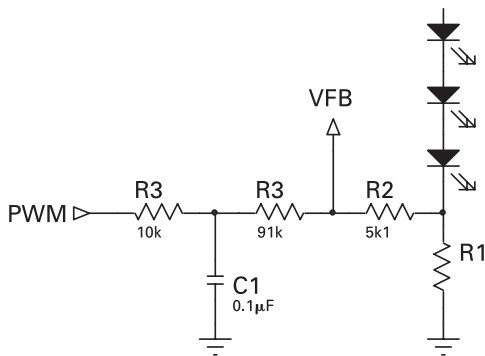

Dimming Control using a logic signal

For applications where the LED current needs to be adjusted in discrete steps a logic signal can be applied as shown in the diagram below. When Q1 is 'off', R1 sets the minimum LED current. When Q1 is 'on', R2 sets the LED current that will be added to the minimum LED current. The formula for selecting values for R1 and R2 are given below:

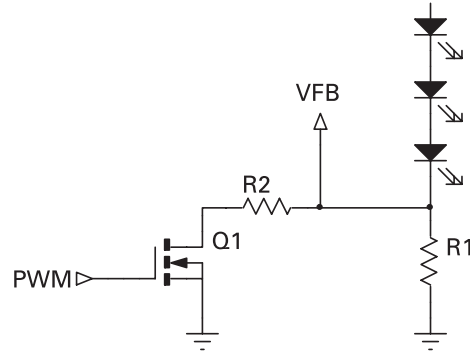

MOSFET 'off'

$$I_{LED(MIN)} = \frac{V_{FB}}{R_{LED}}$$

MOSFET 'on'

$$I_{LED(MAX)} = \frac{V_{FB}}{R_{LED}} + I_{LED(MIN)}$$

where $V_{FB} = 100mV$

ZXLD1937

Open circuit protection

For applications where the LED chain can go open-circuit a Zener diode can be connected across the LED chain preventing over-voltage and possible damage to the main switching transistor. The Zener diodes should be selected by ensuring its voltage rating is higher than the combined forward voltage of the LED chain. Under open circuit conditions the current in the Zener diode defines the output current as:

$$I_z = \frac{V_{FB}}{R_z}$$

To limit battery drain in this fault condition the Zener diode current should be less than 1mA.

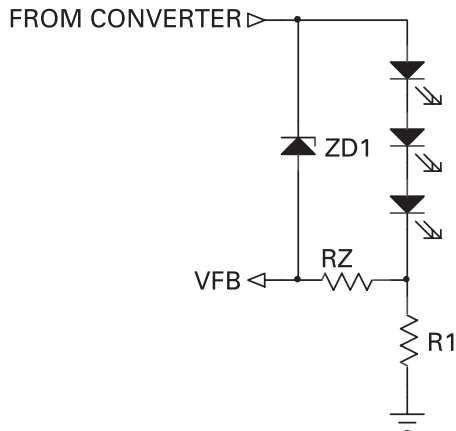

Capacitor selection

A ceramic capacitor grounded close to the GND pin of the package is recommended at the output of the device. Surface mount types offer the best performance due to their lower inductance. A minimum value of 0.22µF is advised, although higher values will lower switching frequency and improve efficiency especially at lower load currents. A higher value will also minimise ripple when using the device to provide an adjustable dc output current.

A good quality, low ESR capacitor should also be used for input decoupling, as the ESR of this capacitor is effectively in series with the source impedance and lowers overall efficiency. This capacitor has to supply the relatively high peak current to the coil and smooth the current ripple on the input supply. A minimum value of 1µF is acceptable if the input source is close to the device, but higher values will improve performance at lower input voltages, when the source impedance is high. The input capacitor should be mounted as close as possible to the IC.

For maximum stability over temperature, capacitors with X7R dielectric are recommended, as these have a much smaller temperature coefficient than other types.

A table of recommended manufacturers is provided below:

Manufacturer	Website
Murata	www.murata.com
Taiyo Yuden	www.t-yuden.com
Kemet	www.kemet.com
AVX	www.avxcorp.com

ZXLD1937

Inductor selection

The choice of inductor will depend on available board space as well as required performance. Small value inductors have the advantage of smaller physical size and may offer lower series resistance and higher saturation current compared to larger values. A disadvantage of lower inductor values is that they result in higher frequency switching, which in turn causes reduced efficiency due to switch losses. Higher inductor values can provide better performance at lower supply voltages. However, if the inductance is too high, the output power will be limited by the internal oscillator, which will prevent the coil current from reaching its peak value. This condition will arise whenever the ramp time ($I_{LX(peak)} \times L/V_{IN}$) exceeds the nominal 5 μ s maximum 'on' time limit for the LX output.

The graphs opposite show the ZXLD1937 performance for given inductor values and different manufacturers.

Recommended inductor values for the ZXLD1937 are in the range 6.8 μ H to 22 μ H. The inductor should be mounted as close to the device as possible with low resistance connections to the LX and VIN pins.

Suitable coils for use with the ZXLD1937 are shown in the table below:

Part No.	L (μ H)	DCR (Ω)	I _{SAT} (A)	Manufacturer
CMD4D11-100MC	10	0.457	0.5	Sumida www.sumida.com
DO1608-103	10	0.16	1.1	Coilcraft www.coilcraft.com
LQH31CN100	10	1.3	0.23	Murata www.murata.com
LB2012Y100MR	10	0.5	0.1	Taiyo Yuden www.t-yuden.co

Diode selection

The rectifier diode (D1) should be a fast low capacitance schottky diode with low reverse leakage at the working voltage. It should also have a peak current rating above the peak coil current and a continuous current rating higher than the maximum output load current.

The table below gives some typical characteristics for diodes that can be used with the ZXLD1937:

Diode	V _F @ 100mA (mV)	I _{FSM} (mA)	I _c (mA)	I _R at 30V (μ A)	Package
ZHCS400	300	1000	400	15	SOD323
ZHCS500	300	1000	500	15	SOT23

Layout considerations

PCB tracks should be kept as short as possible to minimise ground bounce, and the ground pin of the device should be soldered directly to the ground plane. It is particularly important to mount the coil and the input/output capacitors close to the device to minimise parasitic resistance and inductance, which will degrade efficiency. The FB pin is a high impedance input so PCB track lengths to this should also be kept as short as possible to reduce noise pickup. Excess capacitance from the FB pin to ground should be avoided.

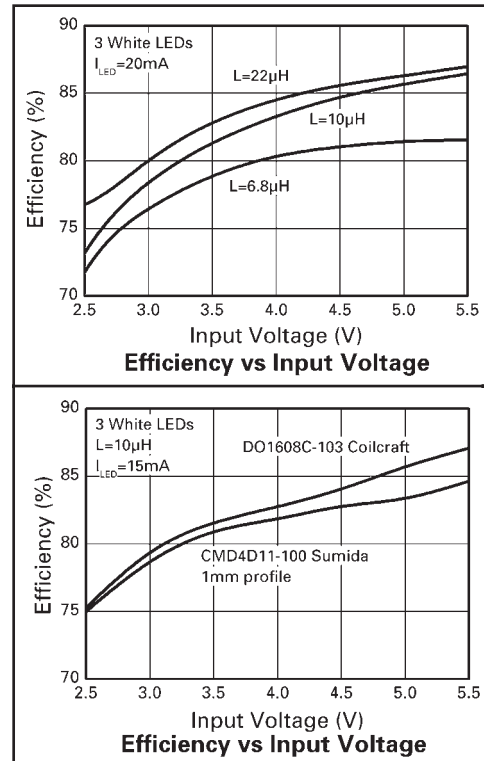

ZXLD1937

REFERENCE DESIGNS

3 LED Driver for Handset LCD Backlight

Circuit Diagram

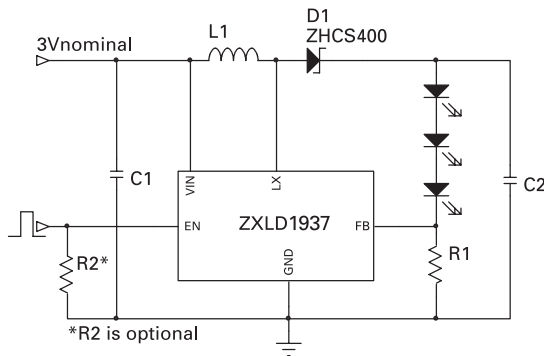

Note: LED current is set to 15mA

*R2 is optional

Bill of materials

Ref	Value	Package	Part Number	Manufacturer	Notes
U1		TSOT23-5	ZXLD1937ET5	Zetex	LED Driver IC
D1	400mA	SOD323	ZHCS400	Zetex	400mA Schottky Diode
L1	10 μ H		CMD4D11-100MC	Sumida	1mm Height Profile
R1	6.8 Ω	0603	Generic	Generic	
R2 ¹	100k Ω	0603	Generic	Generic	
C1	1 μ F	0603	Generic	Generic	
C2	1 μ F	0603	Generic	Generic	
LEDs			NSCW215	Nichia	3pcs per board

Note: R2 is optional. If EN is floating add R2 to shutdown the ZXLD1937 and LEDs. If EN pin can be driven low, R2 is not necessary.

Performance Graphs

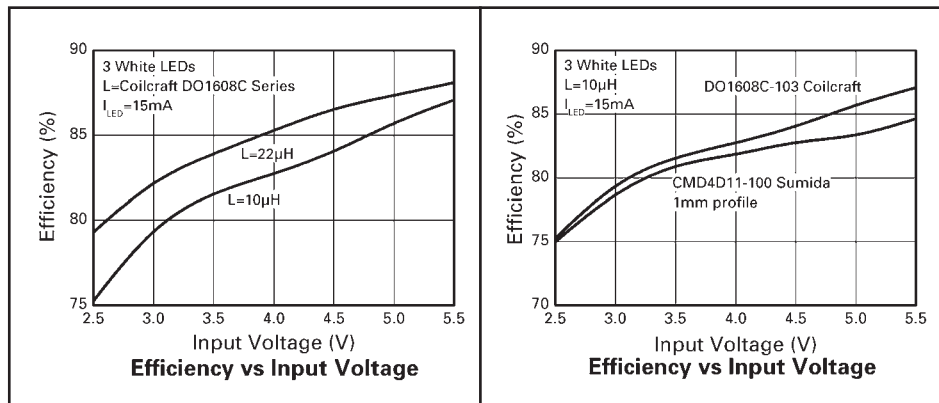

ZXLD1937

4 LED Driver for Handset LCD Backlight

Circuit Diagram

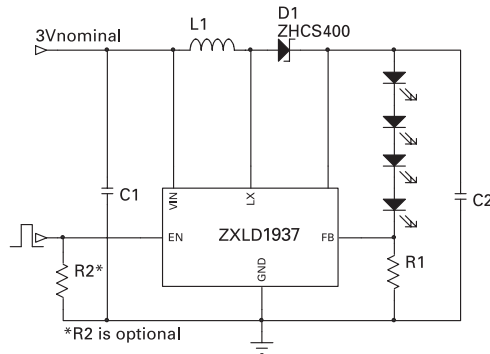

Note: LED current is set to 15mA

Bill of materials

Ref	Value	Package	Part Number	Manufacturer	Notes
U1		TSOT23-5	ZXLD1937ET5	Zetex	LED Driver IC
D1	400mA	SOD323	ZHCS400	Zetex	400mA Schottky Diode
L1	10 μ H		CMD4D11-100MC	Sumida	1mm Height Profile
R1	6.8 Ω	0603	Generic	Generic	
R2 ¹	100k Ω	0603	Generic	Generic	
C1	1 μ F	0603	Generic	Generic	
C2	1 μ F	0603	Generic	Generic	
LEDs			NSCW215	Nichia	4pcs per board

Note: R2 is optional. If EN is floating add R2 to shutdown the ZXLD1937 and LEDs. If EN pin can be driven low, R2 is not necessary.

Performance Graphs

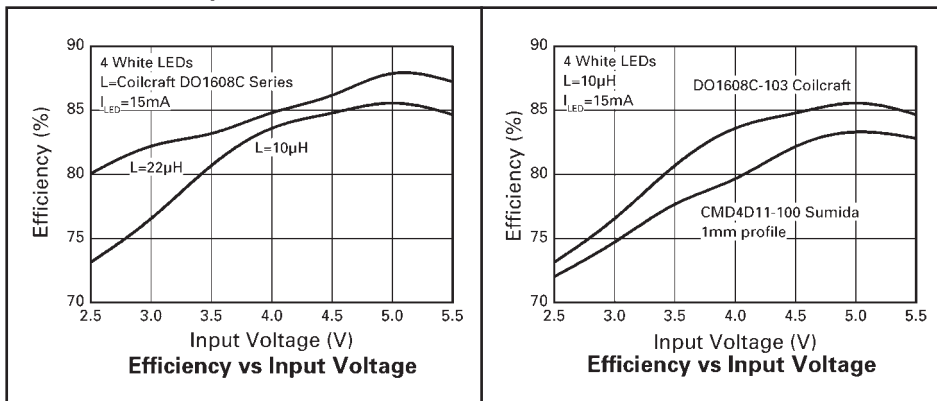

ISSUE 1 - JULY 2004

ZXLD1937

5 LED Driver for Handset Main and Sub Display LCD Backlight

Circuit Diagram

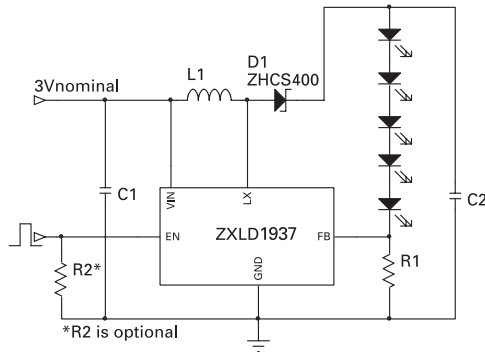

Note: LED current is set to 15mA

Bill of materials

Ref	Value	Package	Part Number	Manufacturer	Notes
U1		TSOT23-5	ZXLD1937ET5	Zetex	LED Driver IC
D1	400mA	SOD323	ZHCS400	Zetex	400mA Schottky Diode
L1	10 μ H		CMD4D11-100MC	Sumida	1mm Height Profile
R1	6.8 Ω	0603	Generic	Generic	
R2 ¹	100k Ω	0603	Generic	Generic	
C1	1 μ F	0603	Generic	Generic	
C2	1 μ F	0603	Generic	Generic	

Note: R2 is optional. If EN is floating add R2 to shutdown the ZXLD1937 and LEDs. If EN pin can be driven low, R2 is not necessary.

Performance Graphs

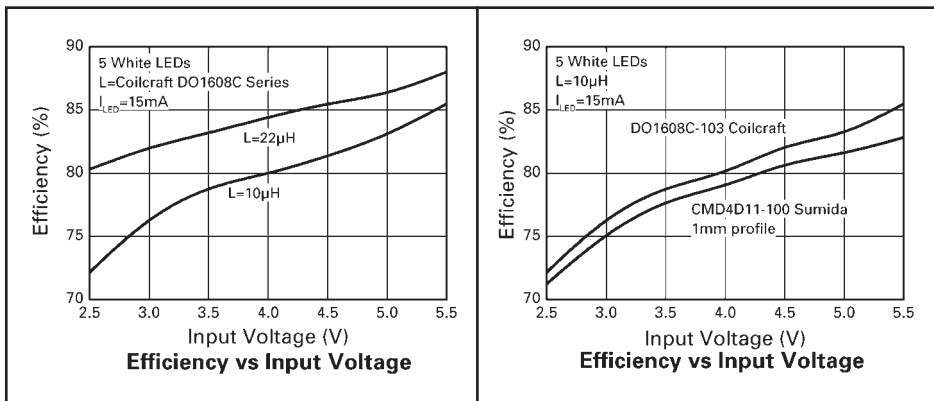

ZXLD1937

6 LED Driver for LCD Backlight

Circuit Diagram

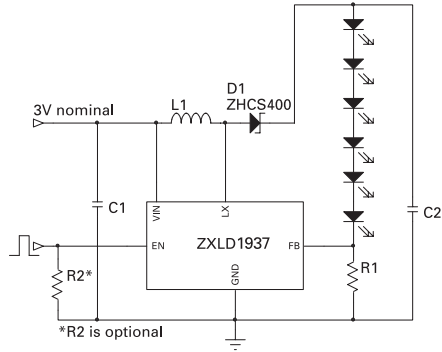

Note: LED current is set to 15mA

Bill of materials

Ref	Value	Package	Part Number	Manufacturer	Notes
U1		TSOT23-5	ZXLD1937ET5	Zetex	LED Driver IC
D1	400mA	SOD323	ZHCS400	Zetex	400mA Schottky Diode
L1	10 μ H		CMD4D11-100MC	Sumida	1mm Height Profile
R1	6.8 Ω	0603	Generic	Generic	
R2 ¹	100k Ω	0603	Generic	Generic	
C1	1 μ F	0603	Generic	Generic	
C2	1 μ F	0603	Generic	Generic	
LEDs			NSCW215	Nichia	6pcs per board

Note: R2 is optional. If EN is floating add R2 to shutdown the ZXLD1937 and LEDs. If EN pin can be driven low, R2 is not necessary.

Performance Graphs

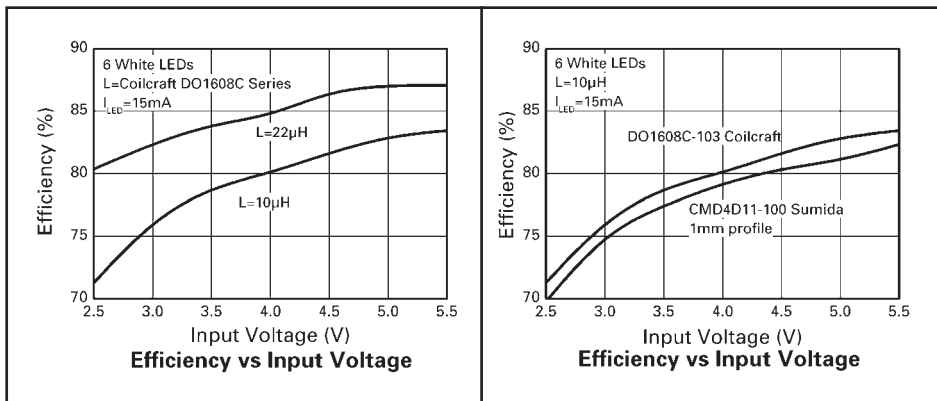

ZXLD1937

PACKAGE OUTLINE - TSOT23-5

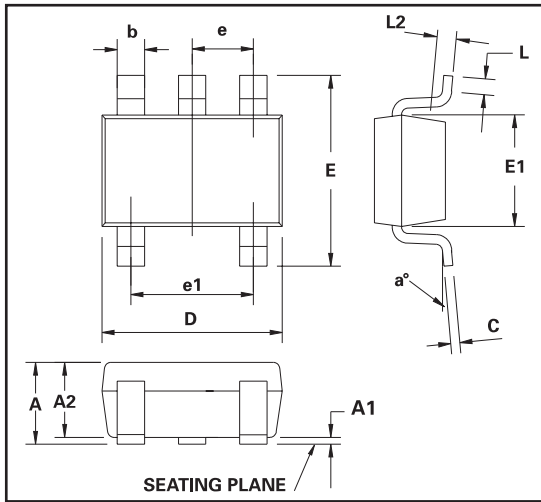

Controlling dimensions are in millimeters. Approximate conversions are given in inches

PACKAGE DIMENSIONS

DIM	Millimeters		Inches		DIM	Millimeters		Inches	
	Min	Max	Min	Max		Min	Max	Min	Max
A	-	1.00	-	0.0393	E1	1.60 BSC		0.062 BSC	
A1	0.01	0.10	0.0003	0.0039	e	0.95 BSC		0.0037 BSC	
A2	0.84	0.90	0.0330	0.0354	e1	1.90 BSC		0.074 BSC	
b	0.30	0.45	0.0118	0.0177	L	0.30	0.50	0.0118	0.0196
c	0.12	0.20	0.0047	0.0078	L2	0.25 BSC		0.010 BSC	
D	2.90 BSC		0.114 BSC		a°	4°	12°	4°	12°
E	2.80 BSC		0.110 BSC		-	-	-	-	-

© Zetex Semiconductors plc 2004

Europe	Americas	Asia Pacific	Corporate Headquarters
Zetex GmbH Streitfeldstraße 19 D-81673 München Germany	Zetex Inc 700 Veterans Memorial Hwy Hauppauge, NY 11788 USA	Zetex (Asia) Ltd 3701-04 Metroplaza Tower 1 Hing Fong Road, Kwai Fong Hong Kong	Zetex plc Lansdowne Road, Chadderton Oldham, OL9 9TY United Kingdom
Telefon: (49) 89 45 49 49 0 Fax: (49) 89 45 49 49 49 europa.sales@zetex.com	Telephone: (1) 631 360 2222 Fax: (1) 631 360 8222 usa.sales@zetex.com	Telephone: (852) 26100 611 Fax: (852) 24250 494 asia.sales@zetex.com	Telephone (44) 161 622 4444 Fax: (44) 161 622 4446 hq@zetex.com

These offices are supported by agents and distributors in major countries world-wide.

This publication is issued to provide outline information only which (unless agreed by the Company in writing) may not be used, applied or reproduced for any purpose or form part of any order or contract or be regarded as a representation relating to the products or services concerned. The Company reserves the right to alter without notice the specification, design, price or conditions of supply of any product or service.

For the latest product information, log on to www.zetex.com



ISSUE 1 - JULY 2004